

Dual Plate Check Valve

Double door Check Valve for clean fluids



TECHNICAL GUIDE: **VH4.2**

Applications

Pump stations

Irrigation

Farm take offs

Compressors

Product Attributes

Non-slam

Wafer design

Approvals/Standards

Seat Class A to ISO 5208

Pressure test to API 598

Quality

ISO 9001:2008 Quality
Management Standard

Double door Check Valve for clean fluids

Features

- Body (optional carbon steel, ductile iron or duplex)
- Disc (optional carbon steel, ductile iron or duplex)
- Upper and lower PTFE thrust bearings
- Standard EPDM Sealing O-Ring (optional NBR or Viton)
- Dual springs for quicker activation, long life, and even distribution of force over both plates
- Fusion bonded epoxy coated body (internal & external)
- Long leaf springs (prevent rubbing of disc on seat)

Technical Data

- Size Range: DN40 - DN1000
- Pressure Class PN10, PN16, PN25
- Face to face: DIN3202-K3
- Temperature Range: -20°C to 100°C (standard EPDM seat)
- -20°C to 80°C (optional NBR seat)
- -20°C to 150°C (optional Viton seat)
- Pressure Testing: AP1598
- Coating: Fusion Bonded Epoxy



FIG. 1

TABLE 1

No	Description	Material
1	Body	Cast Iron
2	Disc	SS316
3	Stem	SS316
4	Spring	SS316
5	Bearing	PTFE
6	Bearing	PTFE
7	Sealing O-Ring	EPDM
8	Hex Screw	SS316
9	Seat	EPDM
10	Eye Bolt	SS316

TABLE 2

DN	FxF	ØD	ØD1	ØD2	R	Weight (kg)
50	43	96	65	40	27	1.3
65	46	110	80	60	35	2.1
80	64	128	94	70	42	2.9
100	64	156	117	88	50	4.3
125	70	187	145	115	64	6.4
150	76	213	171	134	77	9.1
200	89	267	224	182	102.5	15.2
250	114	328	265	220	125	26.5
300	114	375	310	260	146	37
350	127	444	360	298	170	55
400	140	495	410	350	195	80
450	152	558	450	385	215	101
500	152	615	505	438	238	114
600	178	723	624.5	573	292	172
700	229	812	720	680	350	258
800	241	948	825	770	400	322

Other sizes available on request

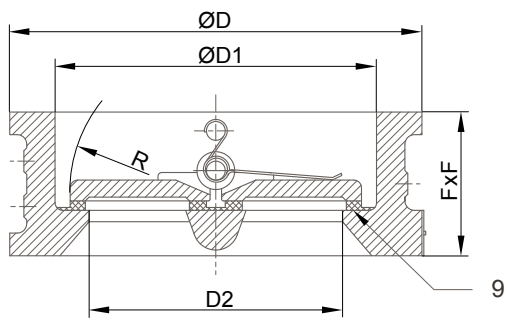

DN50 - DN500
SECTION A - A

FIG. 2

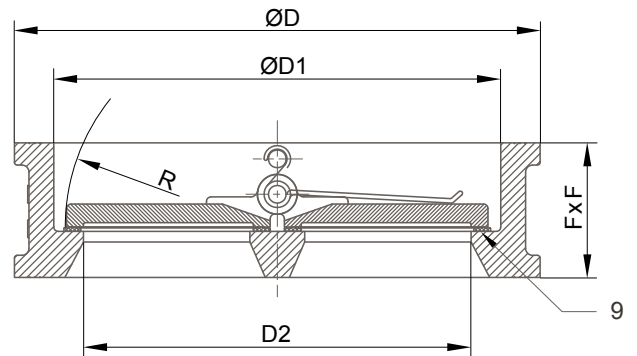

DN600 - DN800
SECTION A - A

FIG. 3

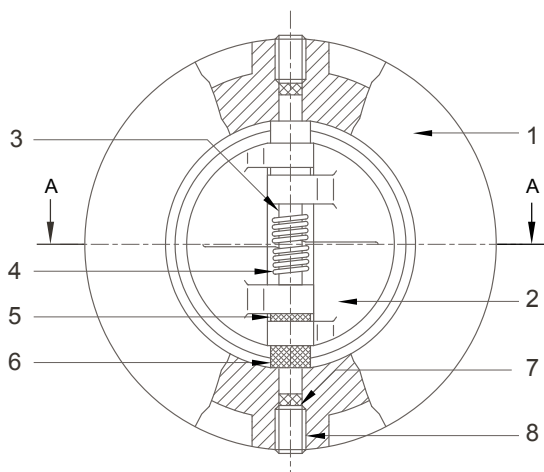

FIG. 4

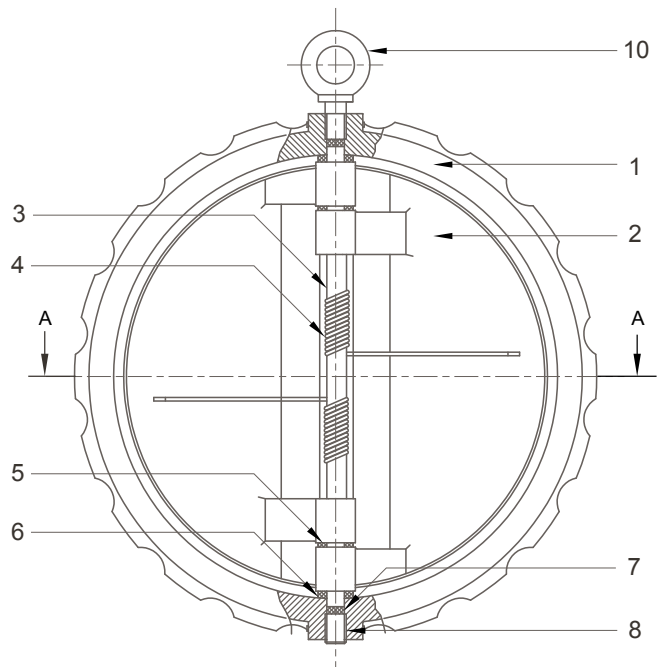

FIG. 5



Scan for more
information

Disclaimer: While every effort has been made to ensure that the information in this document is correct and accurate, users of Hygrade Water product or information within this document must make their own assessment of suitability for their particular application. Product dimensions are nominal only, and should be verified if critical to a particular installation. No warranty is either expressed, implied, or statutory made by Hygrade Water unless expressly stated in any sale and purchase agreement entered into between Hygrade Water and the user.

November 2022

0800 494 723
hygradewater.co.nz

102 Neilson Street
Onehunga, Auckland 1061, New Zealand
PO Box 58142, Botany, Auckland 2163

