

Single Flap Wafer Check Valve

Compact wafer check valve for clean water service.



TECHNICAL GUIDE: **VH4.4**

Applications

Water treatment

Pump stations

Product Attributes

Fits between multiple flange standards

Cast iron body

Stainless steel flap

EPDM seat

Approvals/Standards

Inspection and test API 598

Quality

ISO 9001:2008 Quality Management Standard

Simple low cost, easy to fit wafer check valve

Product Features

This type of Check Valve is simple, low cost and fits between most common flange types. It offers a soft seat for good shut off assisted by the main spring.

Technical Data

- Size: DN50 – DN600
- Working Pressure: PN16
- Face to Face: DIN3202-K3
- Flange Drilling: ANSI125, EN1092PN16, AS2129 TABLE D/E
- Inspection and Test: API598

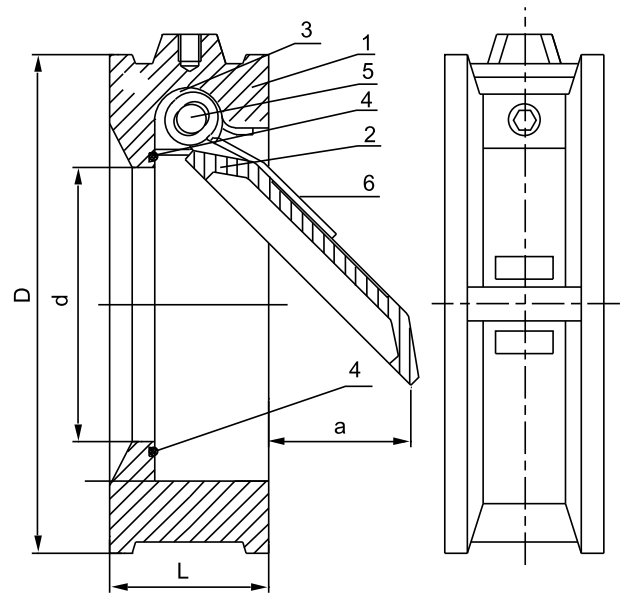

FIG. 1

TABLE 1 Standard Range

Parts	Description	Material	Specification
1	Body	Cast Iron	A126B
2	Disc	Stainless Steel	A351 CF8M
3	Hinge Arm	Stainless Steel	A351 CF8M
4	Seat	EPDM	
5	Hinge Pin	Stainless Steel	AISI410
6	Spring	Stainless Steel	AISI304

TABLE 2

Size		L	D			a	d
DN	NPS		Table D/E	ANSI 125	EN1092 PN16		
50	2"	44.5	98	102	106	29	33
65	2-21/2"	48	111	121	126	30	47
80	3"	51	130	134	141	56	52
100	4"	57	162	172	161	75	76
125	5"	63.5	194	194	191	95	95
150	6"	70	216	220	217	114	121
200	8"	73	273	277	272	156	168
250	10"	79	337	337	337	187	194
300	12"	86	384	407	382	222	241
350	14"	108	444	447	446	229	267
400	16"	108	495	511	515	248	318
450	18"	108	558	546	550	300	356
500	20"	140	615	602	610	324	387
600	24"	152	723	715	733	387	423



Scan for more information

Disclaimer: While every effort has been made to ensure that the information in this document is correct and accurate, users of Hygrade Water product or information within this document must make their own assessment of suitability for their particular application. Product dimensions are nominal only, and should be verified if critical to a particular installation. No warranty is either expressed, implied, or statutory made by Hygrade Water unless expressly stated in any sale and purchase agreement entered into between Hygrade Water and the user.

November 2022