

Georg Fischer Flex Restraint Fittings

Georg Fischer Flex Restraint Fittings are an easy and reliable way to restrain movement in Polyethylene pipes larger than 160mm OD when passing through a wall or structure.



TECHNICAL GUIDE: **PF14.2**

Applications

Pipe Restraint
Thrust Restraint
Manhole Rehab
Slip Lining

Product Attributes

Designed to restrain Polyethylene pipe movement
Permanently attached to pipe by electrofusion
Quick and easy installation

Approvals/Standards

PE3408 resin complies with
ASTM D3350

Quality

ISO 9001:2015 Quality
Management Systems

Georg Fischer Flexi Restraint Fittings are an excellent alternative to using ductile iron spool pieces when a PE pipeline needs restraint.



FIG. 1 Electrofusion Flex Restraints Tested to 10,000 lbs Axial Force

Product Features

- Designed to restrain Polyethylene pipe movement
- Permanently attached to the pipe by electrofusion
- Quick and easy installation
- Flex restraints also can be used for centering and easy sliding of a PE pipe in another pipe
- Engineered for use on HDPE pipe
- Manufactured to work on pipes 160mm OD and larger
- Rated at 31 kN of axial resistance per saddle

Applications

- Pipe restraint
- Thrust restraint
- Manhole rehab
- Slip lining



Flex Restraint Device

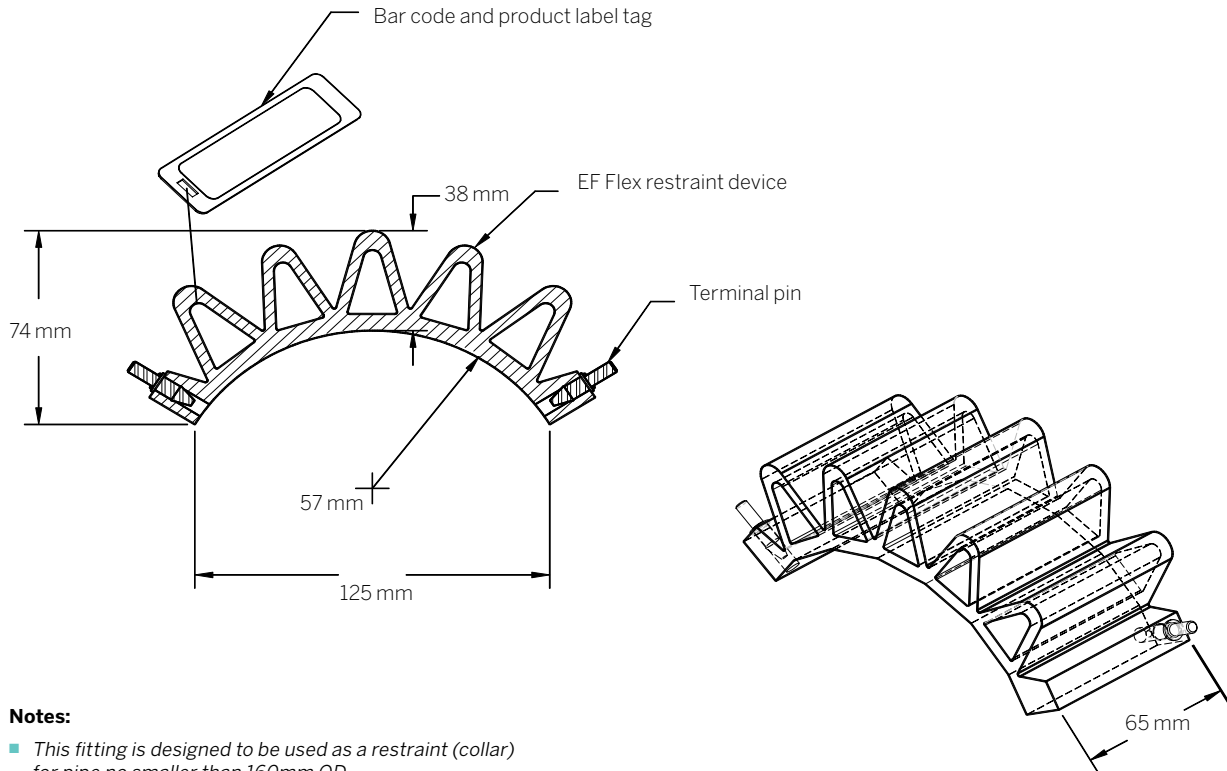

Notes:

- This fitting is designed to be used as a restraint (collar) for pipe no smaller than 160mm OD.
- For standard pipe sizes and radii see radius chart.

Code:

EFRESTRAINTGF
 Main Pipe Size (R) = 160-1600mm
 L = 152mm
 H = 40mm
 W = 63mm

d (mm)	SDR11 Quantity of Restraints Needed	SDR17 Quantity of Restraints
160	2	2
225	2	2
280	3	2
315	4	3
355	5	3
400	6	4
450	8	5
500	8	5
560	11	8
630	13	9
710	14	11
800	16	16
900	18	18
1000	20	20
1200	25	25

Installation Instructions

1. Identify the desired location for the Flex Restraints.
2. Pipe must be clean. Remove all sources of contamination. Isopropyl Alcohol and a clean lint free rag should be used to clean the surface area to be fused.
3. For the purpose of ensuring a good peel of the fusion area, use a marker to randomly mark over the outlined fusion area. This will provide you with a visual gauge while peeling.

Note: Use of a mechanical peeler is recommended.

4. A thin layer of the pipe's surface area must be removed in the area that is to be fused to ensure a quality fusion joint. Peel the fusion area until all your marks have been removed.

Note: Make sure the fusion area remains clean and free of moisture during the installation of the saddle. If contamination of the area occurs after scraping, Isopropyl alcohol and a clean lint free rag should be used to remove contamination.

5. The Flex Restraint must be secured to the scraped area of the pipe surface. This can be accomplished in a variety of ways. Ratchet straps are the recommended application tool due to the ease of use.
6. Tighten the strap until the restraints are conformed to the pipe wall. Make sure the Flex Restraint contacts the pipe over the entire fusion area. If more than one restraint is to be used, make sure that all fittings are in place before fully tightening the ratchet straps.

Note: If multiple restraints are to be used, it is helpful to place the fitting over the scraped area and to secure it in place with masking tape or duct tape until the strap can be applied.

7. Connect the processor leads to the Flex Restraint.

Note: The pin size is 4.7mm. The fusion data can be entered into the processor in either manual mode or bar-code mode. If the data is entered in manual mode, make sure to set the fusion time as stated on the fitting label (40 volts for 140 seconds). The bar-code entry of data automatically sets the fusion parameters.

8. After the fusion cycle is complete, the restraint and clamping device being used must remain in place and be allowed to cool for 15 minutes. The Flex Restraint should be completely cool before it is subjected to any forces.

Caution: The fusion zone of the Flex Restraint gets very hot, and it is also a potential shock hazard. Do not touch the wires during the fusion or cooling time.

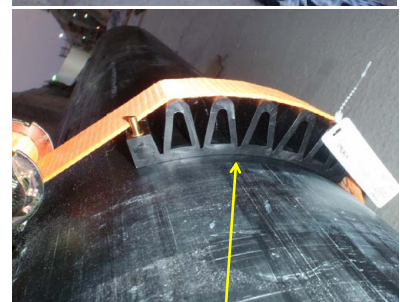

Scan for more information

Disclaimer: While every effort has been made to ensure that the information in this document is correct and accurate, users of Hygrade Water product or information within this document must make their own assessment of suitability for their particular application. Product dimensions are nominal only, and should be verified if critical to a particular installation. No warranty is either expressed, implied, or statutory made by Hygrade Water unless expressly stated in any sale and purchase agreement entered into between Hygrade Water and the user.

April 2023