

# Gillies Pipe Bellows

Single sphere moulded rubber bellows with loose Stainless-Steel flanges are ideal for pump isolation or compensating for minor pipeline misalignment.



TECHNICAL GUIDE: **PF7.1**

## Applications

Pump vibration isolation  
 Limited pipeline misalignment  
 Potable water  
 Raw water

## Product Attributes

Single sphere moulded rubber bellow  
 316 Stainless Steel Flanges  
 PN16 rated

## Approvals/Standards

Flanges to AS4087 Fig. B7 PN16

## Quality

ISO 9001 Quality  
 Management Systems

Single sphere rubber bellows to isolate pump vibration and noise from the surrounding pipe work. Loose flanges allow for easy fitting and minor misalignment.

Pipe bellows consist of a rubber section moulded to shape and fitted with a rotatable stainless-steel flange at each end for connection to flanged pipework.

### Applications

- Compensate for heat-generated expansions
- Compensate for the settlements of terrain or structures
- Absorb machinery vibrations and reduce the noise they produce
- Soften the impact of water hammer
- Create disassembly joints
- Suitable for pressure or suction duty\*
- Can be fitted between tank and pipe work
- Not suitable for buried applications as this will restrict movement of the bellows and pipework.\*\*

**Note:**

- \*Vacuum application bellows must be installed in a neutral position.
- \*\* For buried applications please contact us for alternative solutions.

### Features

- Requires little space to install
- Absorbs axial, lateral and angular movement
- Safe, reliable and durable
- High capacity acoustic damping

### Accessories

- Expansion limit rods - Standard on bellows DN300 and larger.
- Other flange drillings
- HDG flanges

### Testing

- Tested to three times rated pressure

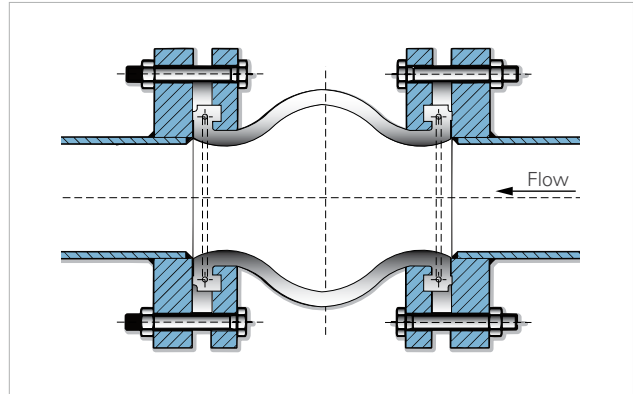

**FIG. 1** Spherical moulded design

### Technical Data

- Size Range: DN40 to DN300
- Pressure Range: PN16
- Vacuum: partial vacuum possible\*
- Temperature Range: - 20°C to +80°C
- Flange Drilling: AS 4087 Fig. B7
- Pressure Tests: 3 times maximum rated pressure
- Outer and Inner Tube Material: EPDM
- Frame: Nylon cord fabric
- Hard wire pressure balance ring
- Retaining Flange Rings: 316 Stainless Steel

### Storage Requirements

- Avoid stacking on top of each other and store on a flat hard surface to avoid compressing the rubber.
- If stored outdoors stack on wooden pallets and cover from sunlight and adverse weather.

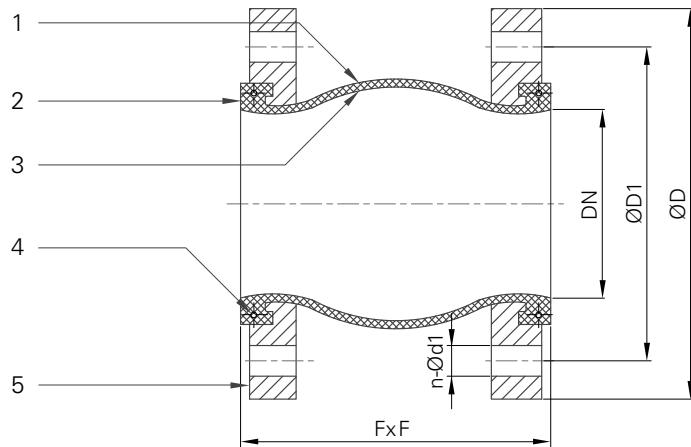

FIG. 2 Dimensional drawing



FIG. 3 DN300 Bellows with Tie Rods

TABLE 1 Product Range

Code	Dimensions				AS2129 Table E	AS4087 Fig. B7	Movements*			
	DN	FxF	ØD	ØD1	n-Ød1	n-Ød1	Axial Elong.	Axial Comp.	Lateral	Angular (°)
BRSS040DF	40	95	135	98	4-14	4-14	6	10	9	15
BRSS050DF	50	105	150	114	4-18	4-18	7	10	10	15
BRSS065DF	65	115	165	127	4-18	4-18	7	13	11	15
BRSS080DF	80	130	185	146		4-18	8	15	12	15
BRSS100DF	100	135	215	178		4-18	10	19	13	15
BRSS150DF	150	180	280	235		8-18	12	20	14	15
BRSS200DF	200	205	335	292		8-18	16	25	22	15
BRSS250DF	250	240	405	356		8-22	16	25	22	15
BRSS300DF**	300	260	455	406		12-22	16	25	22	15

**Note:**

\*Movements are not concurrent.

Maximum deflection in one plane may result in less deflection being available in all other planes.

\*\*Supplied standard with 4 x tie rods

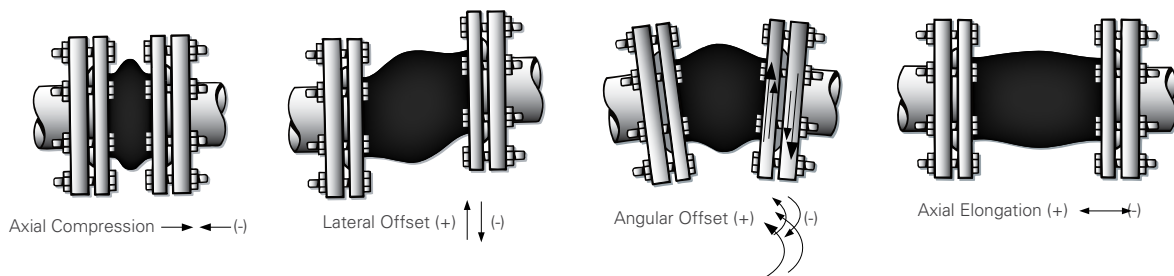
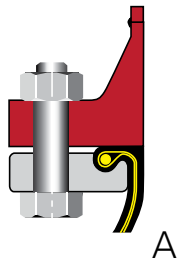

FIG. 4 Movements

## Joints with Beaded End Flanges

Right:

Weld neck flanges with correct ID prevent damage to rubber.



Wrong:

Insure mating flange I.D. is flush with rubber.

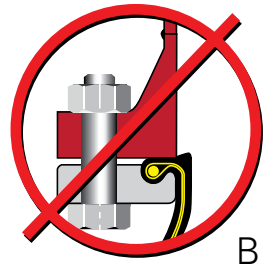

Right:

Flanges with correct ID help prevent damage to rubber.

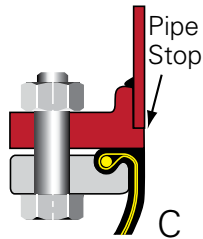

Wrong:

Uneven end of pipe can cause damage to rubber.

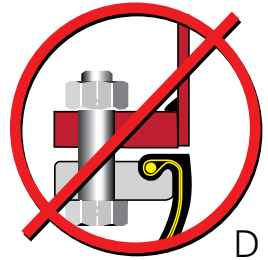

Right:

In case of B, D, F an additional metal gasket can be used to prevent damage to rubber.

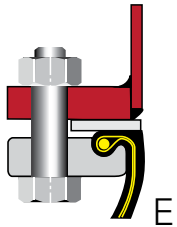

Wrong:

Inner edge of flanges damages rubber.

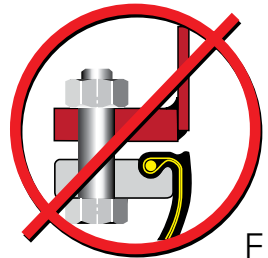

Right:

Well rounded smooth edge prevents damage to rubber.

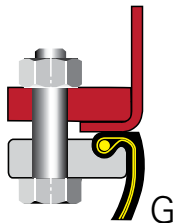

### Installation Guidelines:

- Recommended to use spring washers to avoid nuts working loose from vibration.
- When installing nuts to bolts tighten as per (1) (2) (3) (4) procedure and tighten diagonally and equally.
- Do not over tighten as this may damage the sealing capability.
- Rubber Expansion joints are not designed to support pipe weight. They should be installed as close as possible to the anchor points.

### Maintenance:

- It is recommended to check bolt tightness one to two weeks after installation and for systems with risk of significant temperature changes the bolt tightness should be regularly checked and adjusted as required.



Scan for more information

**Disclaimer:** While every effort has been made to ensure that the information in this document is correct and accurate, users of Hygrade Water product or information within this document must make their own assessment of suitability for their particular application. Product dimensions are nominal only, and should be verified if critical to a particular installation. No warranty is either expressed, implied, or statutory made by Hygrade Water unless expressly stated in any sale and purchase agreement entered into between Hygrade Water and the user.

June 2024

0800 494 723  
 hygradewater.co.nz

102 Neilson Street  
 Onehunga, Auckland 1061, New Zealand  
 PO Box 58 142, Botany, Auckland 2163

**HW** HYGRADE  
 WATER