

CONVERTER MC608 A/B/R/P/I



TECHNICAL GUIDE: **FM1.6**

Application

Abstraction and distribution

District measurements

Revenue and bulk metering

Transport lines

Irrigation

Wastewater and treatment

Leak detection systems

Any remote application with no access to
mains power

Approvals/Standards

OIML Approval

GSM Ready

HART Approval

CONVERTER MC608

The MC608 converter has been designed with the purpose of meeting all the requirements of modern water management systems through a flexible and hybrid electronic, mains powered, battery powered, or both.

Available in:

MC608A: mains powered version 12/24 VAC- dc or 90/264 VAC – Aluminum case; MC608B: battery powered with a useful life of 6 years (max DN600 with full bore units) – Aluminum case;

MC608R: rechargeable battery powered, with solar panel and 12/24 VAC-dc input (max DN600 with full bore units) – Aluminum case; MC608P: mains powered version 12/24 VAC- dc or 90/264 VAC panel version – Polycarbonate case;

MC608I: mains powered version 12/24 VAC- dc or 90/264 with internal battery backup, or rechargeable battery with solar panel – Stainless Steel case.

Applications:

- Abstraction and distribution;
- District measurements;
- Revenue and bulk metering;
- Transport lines;
- Irrigation
- Wastewater and treatment
- Leak detection systems
- Any remote application with no access to mains power.

Installation:

Compact (MC608A/B/R)

Separate (Remote): up to 100 meters cable with mains powered units (MC608A/P/I), or up to 30 meters of cable supplied from factory with battery operated units (MC608B/R). MC608 is compatible with the complete line of sensors from Euromag.

Enclosures:

Reliable and robust IP68 aluminum case MC608A/B/R, Stainless steel IP54 with MC608I for remote installations, and IP67 polycarbonate sturdy case for panel installations MC608P.

Data security:

Excellent data security given by the internal EEPROM memory.

Enhanced data storage of 200.000 lines of data (more than 6 years of data under factory settings).

Cycle memory, old data will be overwritten by new ones when full capacity is reached. A software is supplied with the unit to allow users to communicate with the 608 via Ircom port or RS485 Modbus interface, to any pc, laptop or windows tablet.

Easy data download and management, easy programming.

Advanced self-diagnostic performs a wide range of essential checks automatically.

Multi-level password system to guarantee accessibility and confidentiality.

Accuracy and certifications:

- 2014/35/EU - EN 61010-1:2013 (LVD)
- 2014/30/EU - EN 61326-1:2013 (EMC)
- OIML R49-1:2013 - Class 2

Remote data reading:

With advanced display information, on-site data collection and remote monitoring via GSM/GPRS network, the MC608 allows any customer to access all the information, easily and at no cost.

Add on communication module automatically sends the information via SMS, e-mail (with or without attachment) and to www.euromagdata.com, free access using any browser and with personal ID and password, also on smart phones and tablets.

The MC608 extends the use of electromagnetic flowmeters to water distribution network, allowing a better control of flows in every point of installation.

Add on modules:

Hart protocol option available on MC608A Pressure and temperature reading modules, make the MC608 one of the most complete electronic converter for electromagnetic flowmeters available, giving to the end user a full control over all the main parameters of its network, reducing cost of programming, installation and maintenance.

1 Unit supplying flow pressure temperature, all at the same time.

Always verified:

On-site verification available with the Euromag Field verifier.

Dedicated version:

Special version MC608LB in combination with MUT4000, with Lemo connectors for automotive applications.



MC608I



MC608LB

Features		MC608A	MC608P	MC608B	MC608R	MC608I
Case		Aluminium IP68	Technopolymer IP54	Aluminium IP68	Aluminium IP68	SS IP54
Power supply	90...264 Vac	√	√ ext. supp.		√	
	12/24 Vac/dc	√	√		√	
	Battery powered supply		√	√		
	Rechargeable battery + solar panel			√	√	
Installation	Compact	√		√	√	
	Separate	max 100m	max 100m	max 30m	max 30m	max 100m
Signals I/O	Analogue output 4-20mA	√	√	√ loop pow.	**	√
	Pulse output	√	√	√	√	√
	Hart protocol*	√	√			
	Programmable digital output	√	√		**	√
	Active frequency digital output 0-10 kHz	√	√		**	√
Serial Communication	IrCOM interface	√	√	√	√	
	RS 485 - MODBUS RTU	√	√		**	√
Display	Graphic LCD display 128x64 pixels, 50x25mm visual area, backlit white colour	√	√	√	√	√
Programming	With push buttons on board of converter, by IrCOM interface or via RS485 and MODBUS RTU	√	√	√	√	√
Process Data logger	4 MB flash memory, 200,000 lines of data	√	√	√	√	√
Standards	Type approved OIML R49-1: 2013 - Class 2	√				

* Optional ** Only in recharge mode

	MC608A	MC608P	MC608B	MC608R	MC608I
Temperature	Ambient: -20 ... +60 C° (-4 ... +140 F) Media -25 ... 80 C° (-13 ... +176 F) Storage -40 ... +70 C° (-22 ... +158 F)				
Flow units	ml, cl, dl, l, dal, hl, m3, in3, ft3, gal, USgal, bbl, oz + Custom value				
Add on modules	GSM/GPRS Euromag Module Pressure (1) and temperature (2)				
Totalizers	5 (2 positive, 2 negative, 1 NET)				
Alarms and status	Status icon displayed and alarm logged in the datalogger				
Self-diagnostic	Alarms available: <ul style="list-style-type: none"> • excitation failure • empty pipe on the 4th electrode • high temperature • pulse overlapped • measurement error 				
External verification	Field vericator available for calibration verification and electronic status				
Software for communication and programming	Commissioning (equal settings of meters) - Data print for documentation - Data export (CSV file) - Firmware update - Read instant flowrate - Read and write all non-volatile parameters - Download internal datalogger - View instrument event logger				

MC608A

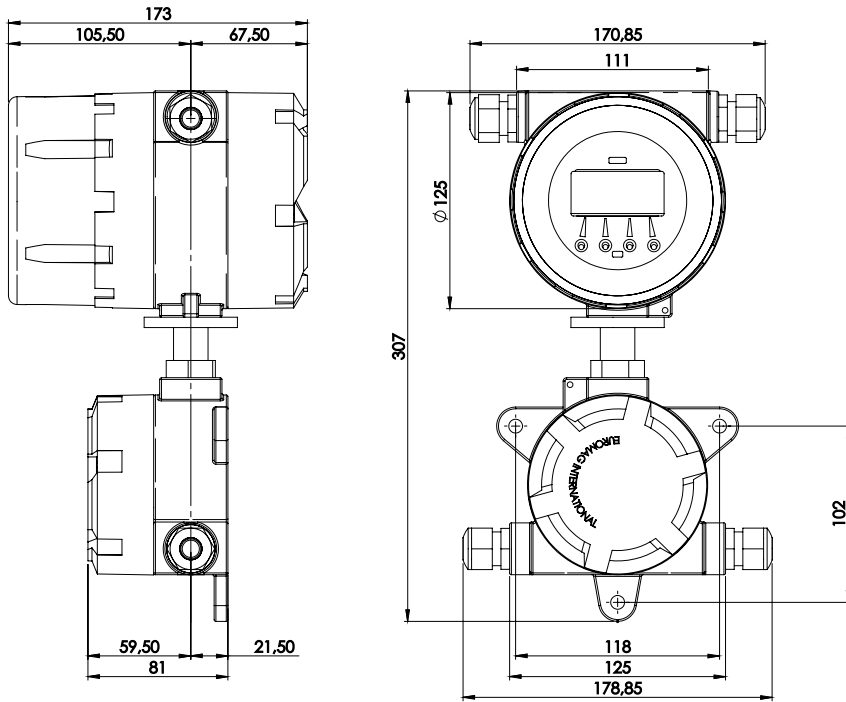

MC608B/R

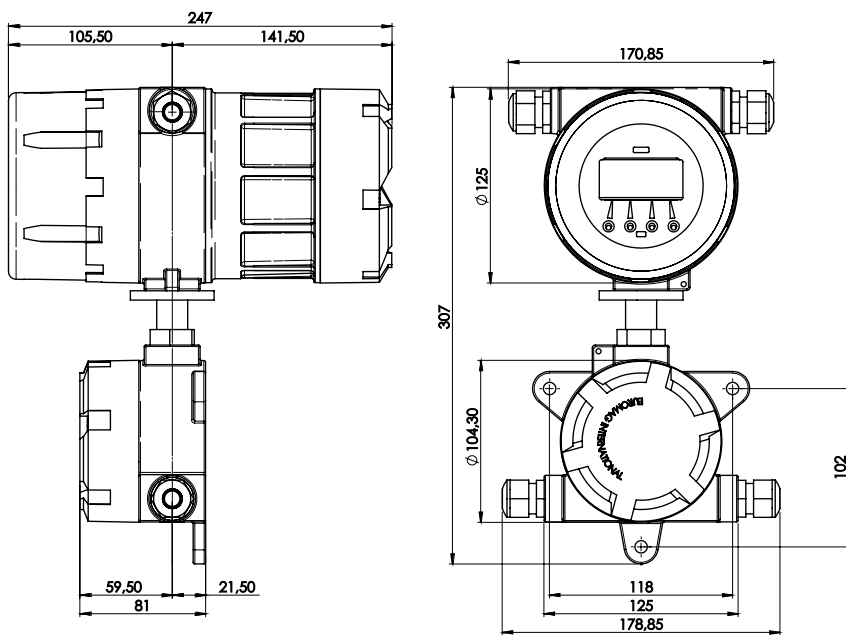

MC608P

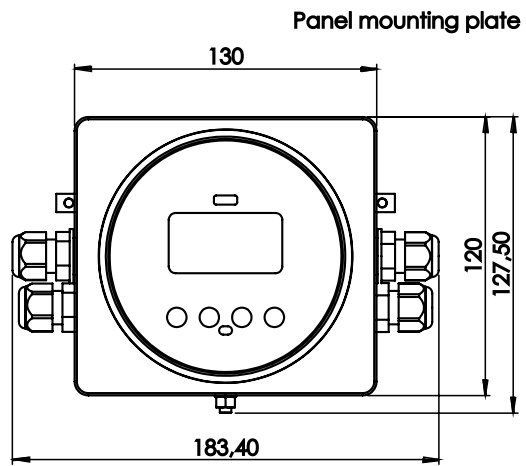
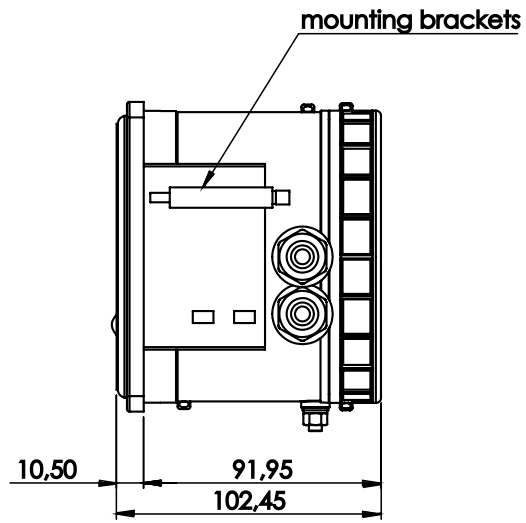

MC608I

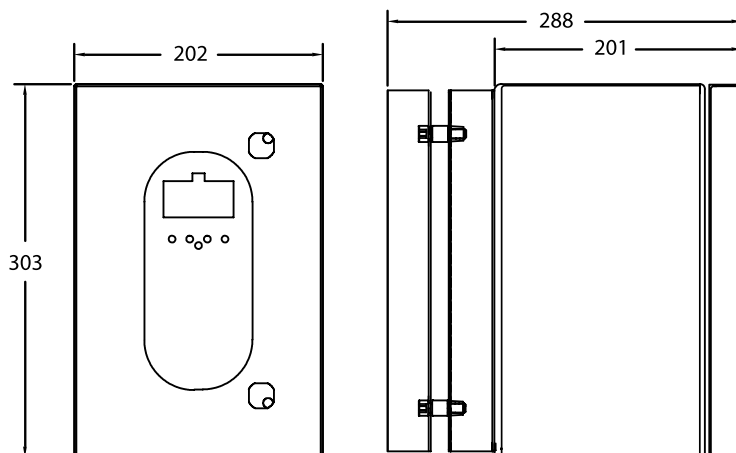



Scan for more
information

Disclaimer: While every effort has been made to ensure that the information in this document is correct and accurate, users of Hygrade Water product or information within this document must make their own assessment of suitability for their particular application. Product dimensions are nominal only, and should be verified if critical to a particular installation. No warranty is either expressed, implied, or statutory made by Hygrade Water unless expressly stated in any sale and purchase agreement entered into between Hygrade Water and the user.

November 2024

0800 494 723
hygradewater.co.nz

102 Neilson Street
Onehunga, Auckland 1061, New Zealand
PO Box 58142, Botany, Auckland 2163

